

PVC SPORT FLOORING

The ultimate flooring,
the ultimate performance

Why
GRABO
sports
flooring?

Wide range of products / applications

- Solutions for competition, training and leisure.
- More options for several applications, from kindergarten, through fitness halls, to high competition level sport facilities.
- 2-10 mm thick sport floorings, special coverings and accessories.



Our vinyl floor coverings are 100% recyclable.
No waste incineration.
No deposition.



Reduced risk of injury
Optimum vertical deformation
Comfort and protection



Reach Conform
The most healthy and environment-friendly solution.

Easy change of direction
Coefficient of friction between 0,4-0,7
Optimal balance of grip and slide



We reuse almost 100% of our manufacturing wastes.
Less emission.



Long term protection
Excellent shock absorption
Genuine joint and cartilage protection



Thanks to our new technology, our products contain recycled raw materials.

Superior for ballsports
Outstanding ball rebound
Imposing sporting performance



THE ULTIMATE PERFORMANCE



Our products are made by technological procedures without using solvents or heavy metals
> less environmental impact.



GraboSAN treatment stops the growth of germs
> reduced risk of contamination in case of injuries.



Due to its special top layer periodical renewal is not necessary. Therefore they can be use continuously, reduced life cycle costs, less chemicals and less energy consumption
> environmentally sound product with reduced maintenance costs.



High energy absorption due to the bottom foam layer
> comfort and protection.
 Optimized deformation shape through the upper foam layer
> easy direction change.

Environmental attributes

- 100 % recyclable
- No waste products
- Compliant with REACH legislation
- ISO 14001 certified company

Benefits of installation

- Available in rolls
- Light weight products
- Less welding
- Damp proof underlay option



MAGYAR OLIMPIAI BIZOTTSÁG
 HUNGARIAN OLYMPIC COMMITTEE



MAGYAR KOSÁRLABDÁZÓK ORSZÁGOS SZÖVETSÉGE
 HUNGARIAN BASKETBALL FEDERATION



MAGYAR KÉZILABDA SZÖVETSÉG
 HUNGARIAN HANDBALL FEDERATION



MAGYAR RÖPLABDA SZÖVETSÉG
 HUNGARIAN VOLLEYBALL FEDERATION



1415 - CPD - 28 (C-49/2008)

MULTISPORT FLOORS

MEGA

highly protective **P2** floor
EN 14904

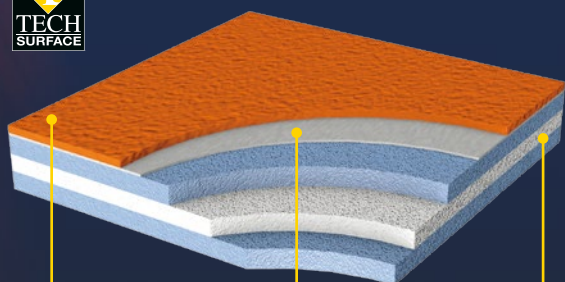

TECH SURFACE
Wear layer

Glass fiber
reinforcement

Combined
Foam Backing

EXTREME / SUPREME / ELITE



highly protective **P1** floors
EN 14904

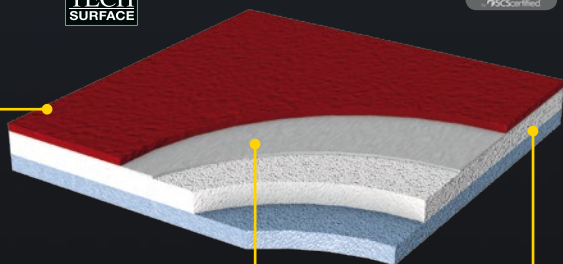

TECH SURFACE
Wear layer

Glass fiber
reinforcement

Combined
Foam Backing

BENEFITS

- High shock absorption due to its Combined Foam Backing > **Long term joint and cartilage protection**
- Stable construction and outstanding ball rebound > **Ideal for game ball sports**
- Excellent foam quality, optimal vertical deformation > **Reduced risk of injury**, higher underfoot comfort
- Unique TECH SURFACE wear layer
 - It contains PUR and Al₂O₃
 - **High wear resistance** due to its micronised Al₂O₃ particles
 - PUR provides **easy to clean** properties
 - Coefficient of friction between 0,4-0,7 > **Easy direction change**
 - No periodical polishing required > **Less energy consumption, less maintenance cost**
 - Optimal specular gloss
- Due to its graboSAN treatment > **Stops the growth of germs**
- 2 m wide rolls > **Less welding and joints**

RECOMMENDED USAGE:

- **Multisport halls**
- **Fencing**
- **Floorball**
- **Gymnastics**

THICKNESS

	Mega 10,0 mm	Extreme 8,0 mm	Supreme 6,7 mm	Elite 6,0 mm
--	---------------------------	-----------------------------	-----------------------------	---------------------------

GUARANTEE

Mega Extreme Supreme	15 years	Elite	10 years
----------------------------	-----------------	-------	-----------------



Colours of MEGA / EXTREME / SUPREME / ELITE

* Elite: min. order 1000 m²

Mega/Extreme/Supreme/Elite



2519-371-273

Mega/Extreme/Supreme/Elite*

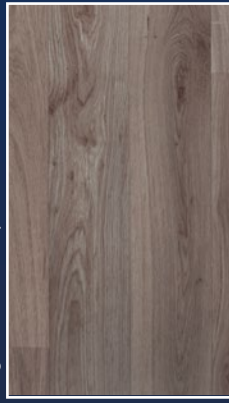

1171-371-273

Mega/Extreme/Supreme/Elite*



2209-371-273

Mega/Extreme/Supreme/Elite*



2000-378-273

Mega/Extreme/Supreme/Elite*



2089-00-273

Mega/Extreme/Supreme/Elite*



4081-00-273

Mega/Extreme/Supreme/Elite*



7143-00-273

Mega/Extreme/Supreme/Elite*



7539-00-273

Mega/Extreme/Supreme/Elite*



6470-00-273

Mega/Extreme/Supreme/Elite*



6115-00-273

Mega/Extreme/Supreme/Elite*

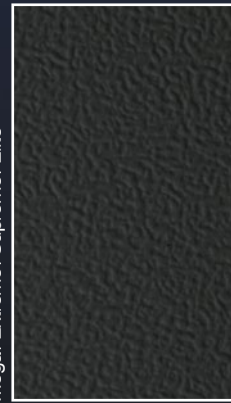

1596-00-273

Mega/Extreme/Supreme/Elite

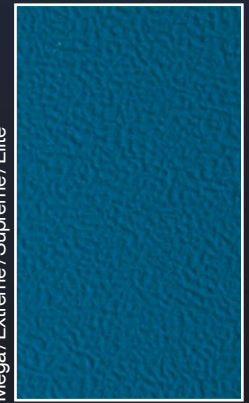

6170-00-273



7483-00-273

Mega/Extreme
Supreme/Elite



1360-00-273

Mega/Extreme
Supreme/Elite



3338-00-273

Mega/Extreme
Supreme/Elite



4289-00-273

Mega/Extreme
Supreme/Elite



4289-00-273

Mega/Extreme
Supreme/Elite

GYMFIT 60

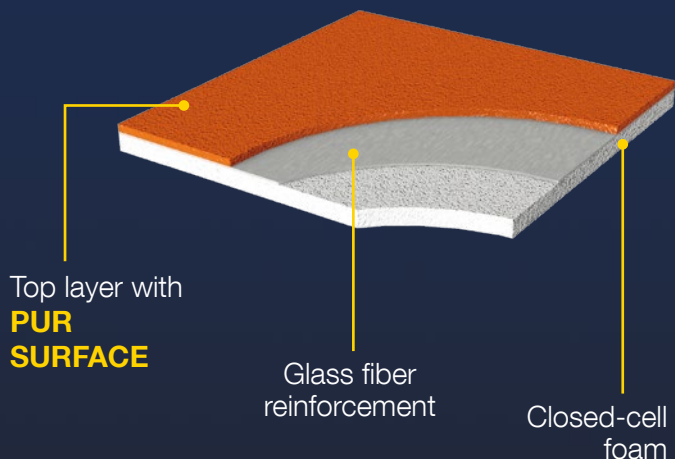

BENEFITS

- Coefficient of friction between 0,4-0,7 > *Optimal balance of grip and slide*
- Easy to clean without periodical polishing > *Less energy consumption, less maintenance cost*
- Optimal specular gloss
- Solvent and heavy metal free products
- **100 % recyclable**
- Contains pre-consumer recycled materials
- Light weight and flexibility; Available in rolls > *Easy and quick installation*
- 2 m wide rolls > *Less welding and joints*

RECOMMENDED USAGE:

- **Fitness halls**
- **Schools**
- **Gymnastics**
- **Kindergarten**

PRIMA STAMINA

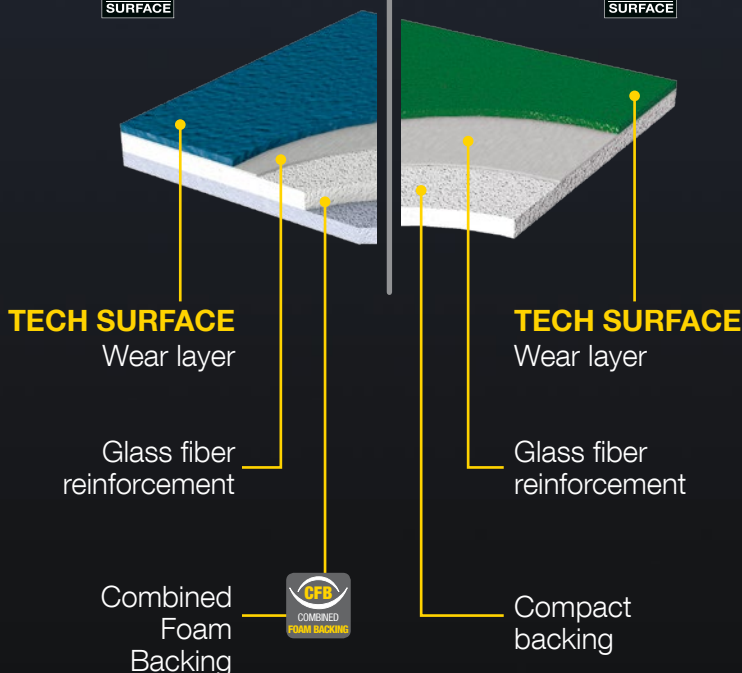

THICKNESS

	Gymfit 60	Prima	Stamina
	6,0 mm	4,5 mm	2,0 mm

GUARANTEE

Gymfit 60	7 years	Prima Stamina	10 years
-----------	----------------	------------------	-----------------



Colours of GYMFIT 60



3338

6,0 mm



3096

6,0 mm

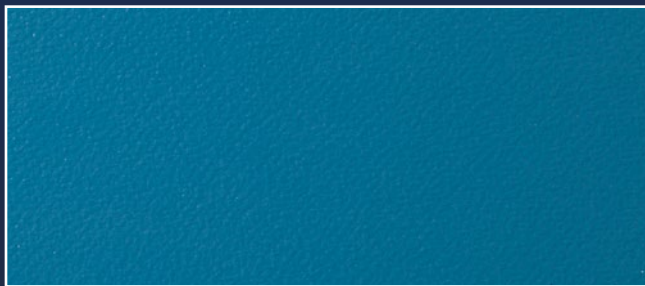

6170

6,0 mm

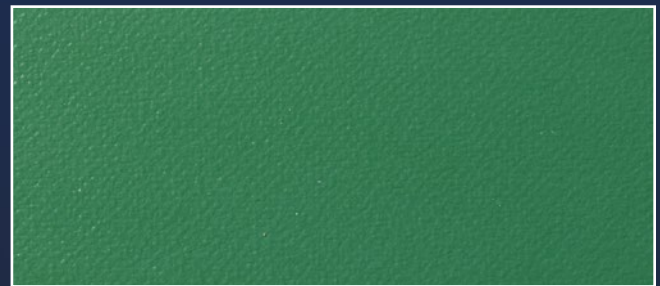

7483

6,0 mm



2519-371

6,0 mm

Colours of PRIMA & STAMINA



3338

Prima / Stamina

4,5/2,0 mm

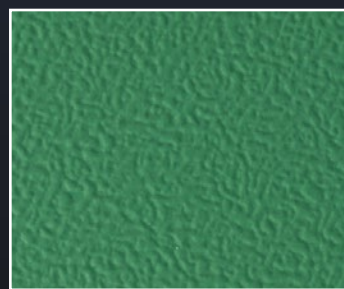

7483

Prima / Stamina

4,5/2,0 mm

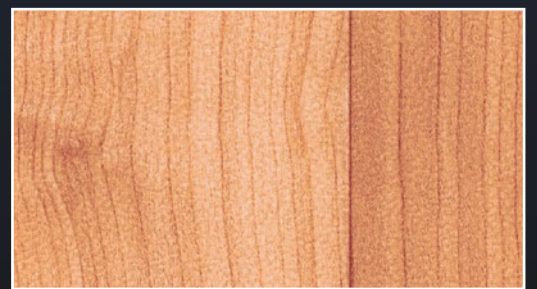

3151-378*

Prima / Stamina

4,5/2,0 mm

*min. order 1000 m²

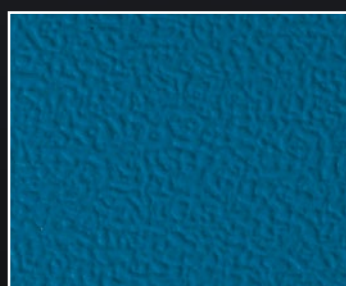

6170

Prima / Stamina

4,5/2,0 mm



2519-371

Prima / Stamina

4,5/2,0 mm

GYMFIT 50

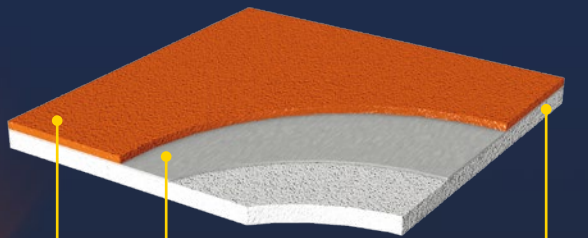

Top layer with **PUR SURFACE**

Glass fiber reinforcement

Closed-cell foam

START / START BASIC PLUS

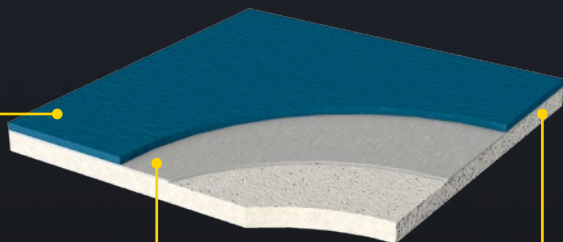

Top layer with **PUR SURFACE**

Glass fiber reinforcement

Closed-cell foam

BENEFITS

- Coefficient of friction between 0,4-0,7
 > **Easy direction change**
- No periodical polishing required
 > **Less energy consumption, less maintenance cost**
- Optimal specular gloss
- Solvent, heavy metal and phtalathe free formulation; Low VOC
 > **Environmentally sound solution**
- **100 % recyclable**
- Contains pre-consumer recycled materials
- Light weight and flexibility; Available in rolls
 > **Easy and quick installation**
- 2 m wide rolls > **Less welding and joints**

RECOMMENDED USAGE:

- **Schools**
- **Kindergarten**
- **Martial arts**
- **Wheelchair sports**

THICKNESS



Gymfit 50
5,0
mm

Start
4,0
mm

Start Basic Plus
3,5
mm

GUARANTEE

Start
Start Basic Plus
Gymfit 50 **7** years



Colours of GYMFIT 50



4000-647

5,0 mm

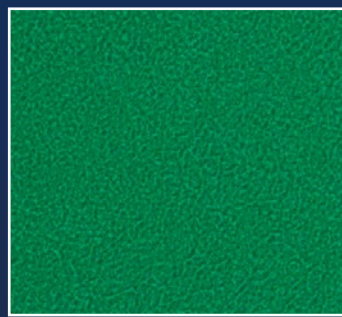

4000-675

5,0 mm



4000-635

5,0 mm



4000-661

5,0 mm



4000-630

5,0 mm



4000-616

5,0 mm



4000-677

5,0 mm

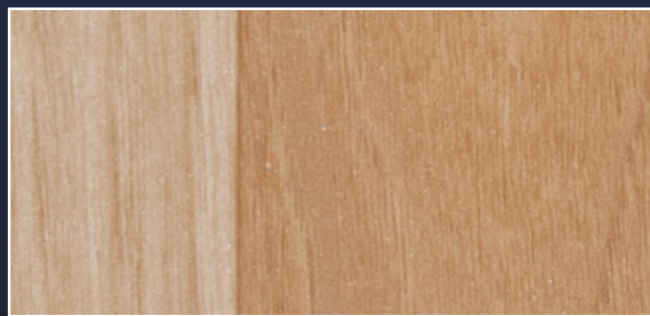

4231-674

5,0 mm



4217-671

5,0 mm

Colours of START



4181-651

4,0 mm

Colours of START / START BASIC PLUS



4000-660

4,0 / 3,5 mm



4000-659

4,0 / 3,5 mm



4000-665

4,0 / 3,5 mm

BADMINTON AND TABLE TENNIS

ROCKET

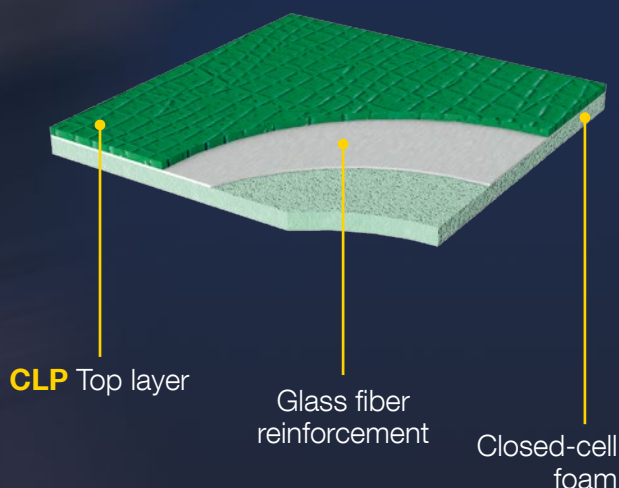

Colours of ROCKET

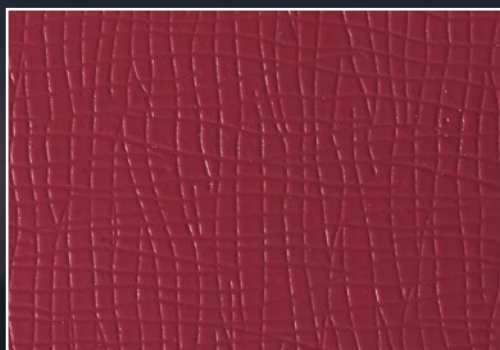

4387

3,8 mm

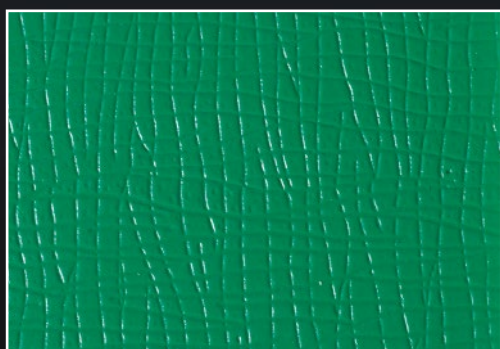

7533

3,8 mm

BENEFITS

- Coefficient of friction between 0,4-0,6
 > **Quick and easy direction change**
- Light weight (Rocket, Start);
 > Easy to roll in and out
 > **Suitable to use temporarily**
- Optimal specular gloss
- Solvent, heavy metal and phtalathe free formulation; Low VOC
 > **Environmentally sound solution**
- **100 % recyclable**
- Contains pre-consumer recycled materials

RECOMMENDED USAGE:

- **Badminton**
- **Table tennis**
- **Kindergarten**
- **Aerobic / Yoga**

THICKNESS



GUARANTEE

7 years



DANCE FLOORS

BENEFITS

- Solution *for several type of dances*
- Double sided ballet floor
- Can be used permanently, or without gluing, temporarily
- Its glass fibre reinforcement provides *excellent dimensional stability*
- One can rolled-in and rolled-out many time without any damages
- **100 % recyclable**
- Light weight and flexibility - *Easy to handle*

RECOMMENDED USAGE:

- **Contemporary**
- **Ballett**
- **Hip-Hop / Jazz**
- **Social**

DUETT

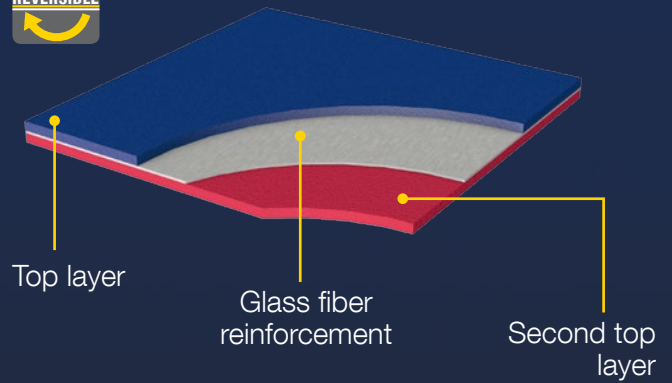

EVIDANCE 25 | EVIDANCE 60

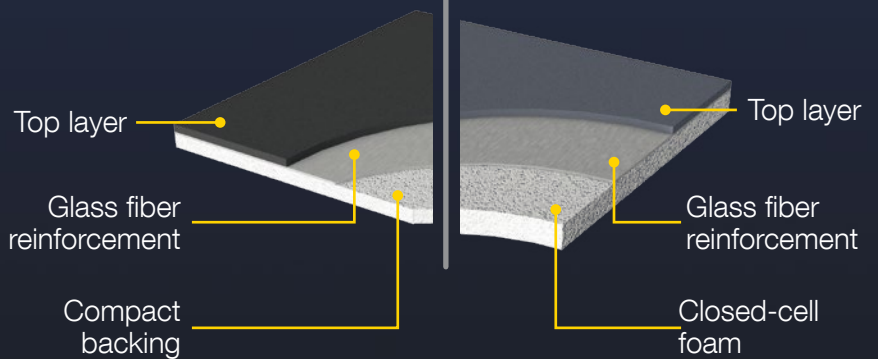

THICKNESS



Duett	Evidence 25	Evidence 60
1,4 mm	2,5 mm	6,0 mm

Colours of DUETT

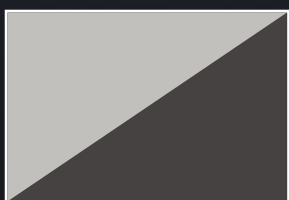

1220/1571 Light Gray / Gray



6270/4252 Blue / Red



6875/1535 Black / Gray



6875/1008 Black / White

Colours of EVIDANCE

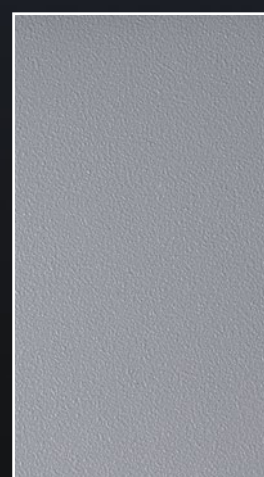

1290



1991

VAPOREX



Damp proof membrane for protection against moisture and for quicker installation.

TECHNICAL DATA	VAPOREX T	VAPOREX 40	VAPOREX
Width EN426	200 cm	145 cm	145 cm
Standard roll length EN426	35 m±10%	25 m±10%	25 m±10% 45 m±10%
Thickness EN428	1,3 mm	4,0 mm	1,4 mm



4250-991 Vaporex T

1,3 mm



1991-S-01/1 Vaporex 40

4,0 mm

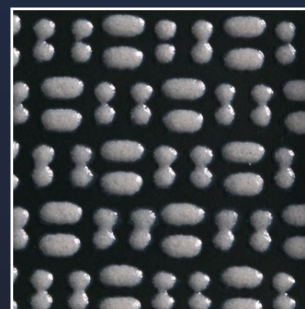

1991-S-03/1 Vaporex

1,4 mm



PROTECTSPORT



Protects the sport flooring during non-sportive events. Easy to roll up and down.

TECHNICAL DATA	PROTECTSPORT	PROTECTSPORT T
Width EN426	140 cm	200 cm
Standard roll length EN426	25 m±10%	35 m±10%
Thickness EN428	1,5 mm	1,0 mm

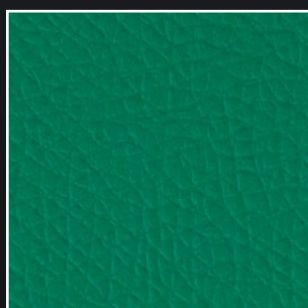

7522 ProtectSport

1,5 mm



1784 ProtectSport

1,5 mm

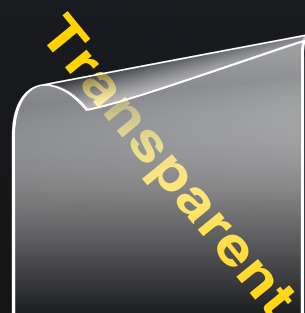

5000-510 ProtectSport T

1,0 mm



ACCESSORIES

WELD



Welding rod, matching to grabo sports flooring designs, guarantees impermeable joints by hot welding.

Diameter	4,5 mm
Roll length	90 m

COLOR

Paints for marking sports ground lines.

Required quantity: 1l for 100 m long and 5 cm wide line.

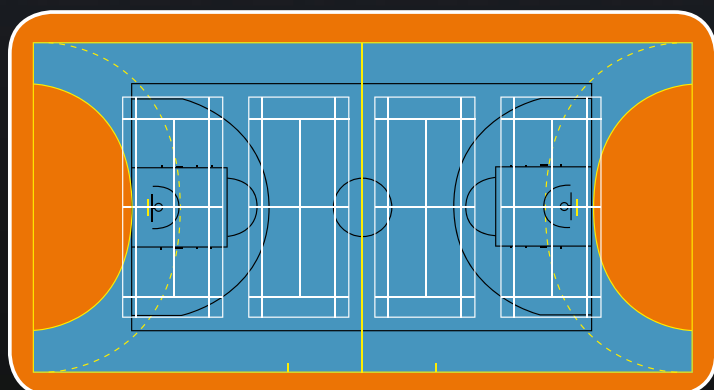

Flooring	Recommended welding rod	
2000		2000
2519 / 4217-671		2066
2209		2219
4000-630		3086
3096		3096
3338		3338
4000-665		3573
4000-635		3553
4000-647		4725
4289		4289
4387		4387
1360		1360
4000-616		6322
1171-371		1246
1286		1286
7483		7483
2089		2243
4181-651		2216
6115		6115
6170 / 4000-659		6170
4000-661		6161
6470		6470
7143		7143
7533 / 4000-675		7533
4000-660		7507
7539		7539
4000-677		7577

Type of the Court	Length of the Marking Line (m)	Color of Paint
Badminton	110	white
Basketball	210	black / dark blue
Floorball	60	white
Handball	230	yellow
Indoor football	210	yellow
Indoor hockey	180	white / light blue / yellow
Netball	150	red
Tennis	150	white / red / yellow
Volleyball	80	green / white

APPLICATION

	MEGA	EXTREME	SUPREME	ELITE	GYMFIT 60	PRIMA	STAMINA	GYMFIT 50	START	START BASIC PLUS	ROCKET	DUETT	EVIDENCE 60	EVIDENCE 25
Multisport halls *														
- competition level	●	●	●	○										
- universities / colleges	●	●	●	●										
- schools	●	●	●	●	●	●		●	●	●	○			
Dance halls														
- ballett							○	○	○	○		●		●
- hip-Hop / jazz							○					●	●	●
- contemporary							○					●	●	●
- social							●							●
Aerobic / Yoga	●	●	●	●	●	●		●	○	○	●		●	○
Badminton		●	●	●	●	●		●	●	●	●			
Billiards / Snooker							●							
Body building							●							
Cardio training					○		●	●	○	○				
Fencing	●	●	●	●	●	●		●	●	●	●			
Floorball	●	●	●	●	●	●		●	○	○	○			
Gymnastics	●	●	●	●	●	●		●	○	○	○		●	
Indoor hockey	●	●	●	●	●	●		●			○			
Kindergarten	●	●	●	●	●	●		●	●	●	●		●	
Locker room					○		●	●	●	●	○		○	●
Martial arts				●	●	●	○	●	●	●	●			
Squash				○	○	○		○	○	○	○			
Table tennis					○			●	●	●	●			
Tennis			●	●		●					○			
Wheelchair sports				○	○	○	●	●	●	●	●			

○ - good ● - recommended ● - best solution

* e.g. Handball, Basketball, Volleyball, Futsal, Netball etc.

References



La Lobilla Sports Complex – Estepona / Spain

Sheraton New York Hotel & Tower Sport Center, USA

Becon Primary School

Sports Hall

Sportshall – Nganjuk

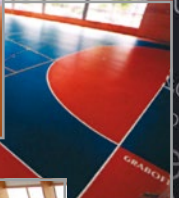

Sports Hall – Cordoba / Spain

Hungarian Language School – N. Zámky / Slovakia

Zavialovo Sportshall / Russia

gym – Algir / Algeria

MEF Education high school – Izmir / Turkey



FK Saturn Sports Hall – Jegorov



Sport hall – Elda

Sports courts – Jaw

Prague

Czech Republic

Sport hall – Ist

Sport

Sport hall – Elda

Sport

Sport hall – Elda

Sport

Sport hall – Elda

Sport

Sport hall – Elda

Sport

Sport hall – Elda

Sport

Sport hall – Elda

Sport

Sport hall – Elda

Sport

Sport hall – Elda

Sport

Sport hall – Elda

Sport

Sport hall – Elda

Sport

Sport hall – Elda

Sport

Sport hall – Elda

Sport

Sport hall – Elda

Sport

Sport hall – Elda

Sport

Sport hall – Elda

Sport

Sport hall – Elda

Sport

Sport hall – Elda

Sport

Sport hall – Elda

Sport

Sport hall – Elda

Sport

Sport hall – Elda

Sport

Sport hall – Elda

Sport

Sport hall – Elda

Sport

Sport hall – Elda

Sport

Sport hall – Elda

Sport

Sport hall – Elda

Sport

Sport hall – Elda

Sport

Sport hall – Elda

Sport

Sport hall – Elda

Sport

Sport hall – Elda

Sport

Sport hall – Elda

Sport

Sport hall – Elda

Sport

Sport hall – Elda

Sport

Sport hall – Elda

Sport

Sport hall – Elda

Sport

Sport hall – Elda

Sport

Sport hall – Elda

Sport

Sport hall – Elda

Sport

Sport hall – Elda

Sport

TECHNICAL DATA

MEGA

EXTREME

SUPREME

ELITE

GYMFIT 60

PRIMA

STAMINA

GYMFIT 50

START

START BASIC PLUS

ROCKET

DESCRIPTION

Thickness	mm	EN ISO 24346	10,0	8,0	6,7	6,0	6,0	4,5	2,0	5,0	4,0	3,5	3,8
Weight	kg/m ²	EN ISO 23997	5,3	4,2	3,8	3,7	3,5	2,8	2,8	2,9	2,7	2,3	2,5
Standard roll leng	m	EN ISO 24341	2	2	2	2	2	2	2	2	2	2	2
Maximal roll length	fm	EN ISO 24341	15	15	20	20	20	20	20	20	20	20	16; 20

CLASSIFICATION

Product specification			EN 14904	EN 14904	EN 14904	EN 14904	EN 651	EN 651	EN 649	EN 651	EN 651	EN 651	EN 651
Impact sound insulation	ΔL_w (dB)	EN ISO 717-2	21	21	22	21		21		16			
Flammability		NF P 92-512	M3	M3	M3	M3	M3			M3			
		EN 13501	Cfl - s1	Cfl - s1	Cfl - s1	Cfl - s1	Cfl - s1	Cfl - s1	Cfl - s1	Cfl - s1	Cfl - s1	Cfl - s1	Cfl - s1
		ÖNORM B3810/B3800/2	B1 - Q1	B1 - Q1	B1 - Q1	B1 - Q1	B1 - Q1			B1 - Q1			

SPORT PROPERTIES

Rotational friction		EN13036-4	80-110	80-110	80-110	80-110	80-110	80-110		80-110	80-110	80-110	80-110
		Pr EN 14903	0,4-0,6	0,4-0,6	0,4-0,6	0,4-0,6	0,4-0,6		0,4-0,6				
Shock absorption	%	DIN 18032	41	34	31	30	21	22		17	12	12	
Shock absorption	%	EN 14808	38	31	28	27	18	19		14	9	9	
Vertical deformation	mm	EN 14809	1,5	1,1	1,08	0,96		0,7		0,33	0,4	0,4	
Ball rebound	%	EN 12235	97	100	98	99	98	98	> 90	100	100	100	> 90
Specular gloss		EN 2813	≤ 30	≤ 30	≤ 30	≤ 30	≤ 30	≤ 30	≤ 30	≤ 30	≤ 30	≤ 30	≤ 30

TECHNICAL CHARACTERISTIC

Dimensional stability	max	EN ISO 23999	+/- 0,2%	+/- 0,2%	+/- 0,2%	+/- 0,2%	+/- 0,2%	+/- 0,2%	+/- 0,2%	+/- 0,2%	+/- 0,2%	+/- 0,2%	+/- 0,2%
Indentation resistance	mm	EN 1516	<0,5	<0,5	<0,5	<0,5	<0,5	<0,5	<0,5	<0,5	<0,5	<0,5	<0,5
Resistance to a rolling load	1500 N	EN 1569	1500	1500	1500	1500		1500	1500	1500			
Colour fastness		ISO 105 B02	6	6	6	6	6	6	6	6	6	6	6
Abrasion resistance (H18 wheel)	≤ 1000 mg / 1000 cycles	EN ISO 5470-1	< 250	< 250	< 250	< 250	< 250	< 250	< 250	< 250	< 250	< 250	< 250

Graboplast Floor Covering Manufacturers Ltd.

H-9023 Győr, Fehérvári út 16/b. Telefon: (+36) 96 506-100

www.graboplast.hu